

# **JL4002A**

## **CF to IDE Bridge Controller**



Revision: 1.1

Date: 10/26/2004

**JEILIN Technology Co., Ltd.**

8F, No.179, Jian Yi Rd., Chung Ho,  
Taipei Hsien, Taiwan

TEL : 886-2-82215466    FAX : 886-2-82215456



Table of Contents

<b>0. REVISION HISTORY .....</b>	<b>3</b>
<b>1. GENERAL DESCRIPTION.....</b>	<b>4</b>
<b>2. FEATURES .....</b>	<b>4</b>
<b>3. APPLICATIONS .....</b>	<b>4</b>
<b>4. BLOCK DIAGRAM .....</b>	<b>5</b>
<b>5. PIN DESCRIPTIONS.....</b>	<b>6</b>
<b>6. ELECTRICAL CHARACTERISTICS.....</b>	<b>11</b>
<b>7. PACKAGE DIAGRAMS .....</b>	<b>12</b>



## 0. Revision History

Revision	Description of Changes	Date
1.0	First Release	2004/1/13
1.1	Change register description	2004/10/26



## 1. General Description

The JL4002A is a highly-compatible, low cost CF to ATA disk interface (IDE) bridge controller, which integrates CF interface, IDE interface, and 3-wire serial interface for device controller can download CIS data CIS RAM. In True-IDE mode, it can support PIO mode up to mode 4, Multiword DMA up to mode 2, and Ultra DMA mode up to mode 4 transfer.

## 2. Features

- Compliant with CF+ and Compact Flash Specification Revision 3.0
- Support all CF modes: Memory, Contiguous IO, Primary IO, Secondary IO, and True IDE modes
- Support PIO Mode 4 in True IDE mode
- Support Multiword DMA Mode 2 in True IDE mode
- Support Ultra DMA Mode 4 in True IDE mode
- Support 8-bit/16-bit data transfer on CF data bus & 16-bit access on IDE data bus
- Compliant with ATA/ATAPI-6 Specification
- Special serial interface to be controlled by device controller
- Embedded Task-File registers are provided for host accessing and device controller checking
- Embedded internal 256 bytes of CIS RAM
- Built-in oscillator circuit using external 20 Mhz crystal
- Embedded PLL
- Support power saving function for device
- Dual clock outputs (1x and 0.5x of crystal frequency)
- 3.3V, 96 Flip-chip package

## 3. Applications

- Compact-Flash+ Type II Micro-drive Card
- IDE/Compact-Flash Adapter



#### 4. Block Diagram

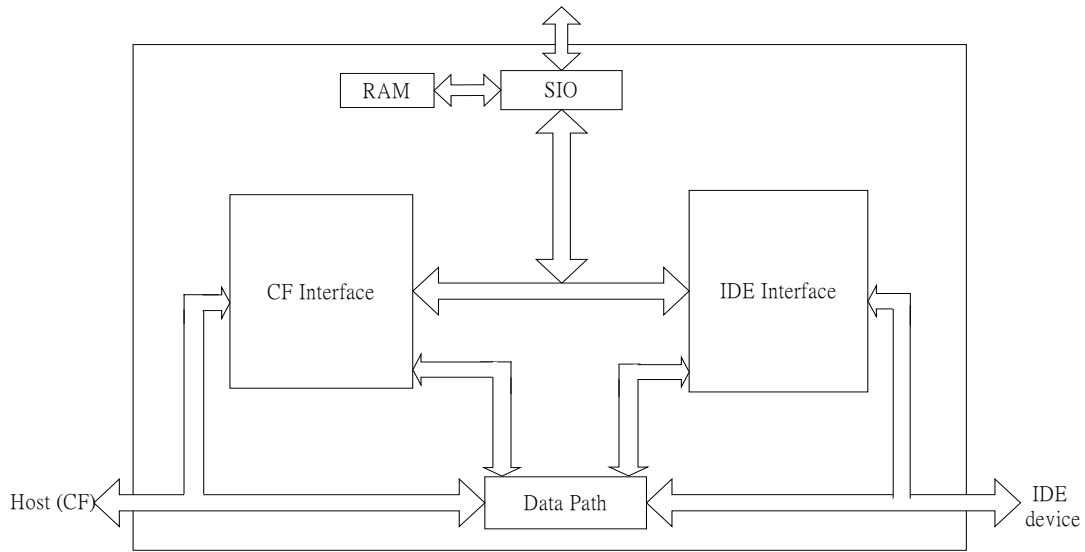



## 5. Pin Descriptions

Pin Name	Pin No.	Type	Description
CF_A0	E2	I	Memory mode: CF Address bit 0 I/O mode: CF Address bit 0 True IDE mode: CF Address bit 0
CF_A1	F2	I	Memory mode: CF Address bit 1 I/O mode: CF Address bit 1 True IDE mode: CF Address bit 1
CF_A2	G1	I	Memory mode: CF Address bit 2 I/O mode: CF Address bit 2 True IDE mode: CF Address bit 2
CF_A3	H1	I	Memory mode: CF Address bit 3 I/O mode: CF Address bit 3
CF_A4	H2	I	Memory mode: CF Address bit 4 I/O mode: CF Address bit 4
CF_A5	I7	I	Memory mode: CF Address bit 5 I/O mode: CF Address bit 5
CF_A6	J7	I	Memory mode: CF Address bit 6 I/O mode: CF Address bit 6
CF_A7	J6	I	Memory mode: CF Address bit 7 I/O mode: CF Address bit 7
CF_A8	J5	I	Memory mode: CF Address bit 8 I/O mode: CF Address bit 8
CF_A9	I5	I	Memory mode: CF Address bit 9 I/O mode: CF Address bit 9
CF_A10	J3	I	Memory mode: CF Address bit 10- I/O mode: CF Address bit 10
CF_D0	E3	B8	CF Data bit 0
CF_D1	D2	B8	CF Data bit 1
CF_D2	D3	B8	CF Data bit 2
CF_D3	G9	B8	CF Data bit 3
CF_D4	I11	B8	CF Data bit 4
CF_D5	J11	B8	CF Data bit 5
CF_D6	J9	B8	CF Data bit 6
CF_D7	J8	B8	CF Data bit 7
CF_D8	D1	B8	CF Data bit 8



Pin Name	Pin No.	Type	Description
CF_D9	C1	B8	CF Data bit 9
CF_D10	C2	B8	CF Data bit 10
CF_D11	H11	B8	CF Data bit 11
CF_D12	H10	B8	CF Data bit 12
CF_D13	I10	B8	CF Data bit 13
CF_D14	K10	B8	CF Data bit 14
CF_D15	K9	B8	CF Data bit 15
/CF_CS0	I8	I, U	Memory mode: CF Card Enable (-CE1) I/O mode: CF Card Enable (-CE1) True IDE mode: chip select for the task file registers
/CF_CS1	K8	I, U	Memory mode: CF Card Enable (-CE2) I/O mode: CF Card Enable (-CE2) True IDE mode: It is used to select the Alternate Status Register and the Device Control Register
/CF_WE	K5	I, U	Memory mode: CF write strobe I/O mode: CF write strobe True IDE mode: It is not used and should be connected to VCC by the host.
/CF_OE	J4	I, U	Memory mode: It is used to read data from CF card of CF <sup>+</sup> card in memory mode and to read the CIS and configuration registers. I/O mode: It is used to read CIS and configuration registers. True IDE mode: To enable True IDE mode this signal should be grounded by the host.
/CF_IOWR	K4	I, U	Memory mode: not used. I/O mode: CF IO write strobe. True IDE mode: CF IO write strobe (non-Ultra DMA mode) or STOP (Ultra DMA mode).
/CF_IORD	K3	I, U	Memory mode: not used. I/O mode: CF IO read strobe. True IDE mode: CF IO read strobe (non-Ultra DMA mode) or /HDMARDY (Ultra DMA mode) or HSTROBE (Ultra DMA mode)
CF_WII	J2	O8, T	CF Write protect (Memory mode) or -IOCS16 (I/O, True IDE mode) Memory mode: CF Write protect. I/O mode: It is used for the -I/O selected is 16 bit port (-IOIS16) function. A low signal indicates that a 16 bit or odd byte only operation can be performed at the addressed port.



Pin Name	Pin No.	Type	Description
			True IDE mode: This output signal is asserted low when this device is expecting a word data transfer cycle (-IOIS16).
CF_RII	K6	O4, T	Memory mode: It is set high when the card is ready to accept a new data transfer operation and held low when the card is busy. I/O mode: Interrupt request, active low True IDE mode: Interrupt request, active high
CF_RESET	H3	I, U	CF Hardware Reset Memory mode: Hardware Reset, active high I/O mode: Hardware Reset, active high True IDE mode: Hardware Reset, active low
/CF_REG	F3	I, U	Memory mode: Attribute memory select I/O mode: This signal must be active (low) during I/O cycles when I/O address is on the bus. True IDE mode: Not used
/CF_WAIT	G3	O4, T	Memory mode: It is driven to low by the card to signal the host to delay completion of a memory or I/O cycle that is in progress. I/O mode: Same function as in memory mode. True IDE mode: It is used as IORDY (non-Ultra DMA mode) or /DDMARDY (Ultra DMA mode) or DSTROBE (Ultra DMA mode).
/CF_INPACK	G2	O4, T	CF input acknowledge Memory mode: Not used I/O mode: CF input acknowledge True IDE mode: DMA request (Ultra DMA mode)
/CF_CD0	B1	O4, T	The CF card detect pin is connected to ground on the card. It is used by the host to determine that the card is fully inserted into its socket.
/CF_CD1	C6	O4, T	CF card detection, same as /CF_CD0 pin
IDE_A0	B5	O4, T	IDE Address bit 0
IDE_A1	C5	O4, T	IDE Address bit 1
IDE_A2	A4	O4, T	IDE Address bit 2
IDE_D0	A7	B4	IDE Data bit 0
IDE_D1	A8	B4	IDE Data bit 1
IDE_D2	B9	B4	IDE Data bit 2
IDE_D3	D9	B4	IDE Data bit 3
IDE_D4	A10	B4	IDE Data bit 4
IDE_D5	B11	B4	IDE Data bit 5



Pin Name	Pin No.	Type	Description
IDE_D6	D10	B4	IDE Data bit 6
IDE_D7	E11	B4	IDE Data bit 7
IDE_D8	D11	B4	IDE Data bit 8
IDE_D9	C11	B4	IDE Data bit 9
IDE_D10	C10	B4	IDE Data bit 10
IDE_D11	E10	B4	IDE Data bit 11
IDE_D12	A9	B4	IDE Data bit 12
IDE_D13	B8	B4	IDE Data bit 13
IDE_D14	C7	B4	IDE Data bit 14
IDE_D15	B7	B4	IDE Data bit 15
/IDE_IOW	A6	O4, T	IO write strobe (non-Ultra DMA mode) or STOP (Ultra DMA mode)
/IDE_IOR	B6	O4, T	IO read strobe (non-Ultra DMA mode) or /HDMARDY (Ultra DMA mode) or HSTROBE (Ultra DMA mode)
IDE_IRQ	A5	I, D	Interrupt request, active high
/IDE_RESET	E9	O4, T	Hardware Reset, active low
/IDE_DMACK	B4	O4	DMA acknowledge
IDE_DMARQ	A3	I	DMA request
IDE_IORDY	J1	I, U	IORDY (non-Ultra DMA mode) or /DDMARDY (Ultra DMA mode) or DSTROBE (Ultra DMA mode)
/PORST	F10	I, U	Power on reset
POWERON	G11	O4	This signal will be set when /PORST signal is active or when a command is received while bridge is in power saving mode. It will remain High until commanded by the device controller via serial bus to set to low (power saving). It is used to indicate this chip whether it is in power saving mode or not.
SIO_ENABLE	F11	I	Serial port enable signal
SIO_CLK	F9	I	Serial clock
SIO_DATA	G10	B4	serial data line
PXIN	A2	ICLK	Crystal terminal or oscillator input
PXOUT	B3	OCLK	Crystal terminal
CLKOUT_20MHz	I2	O4, T	Clock output. Its clock rate is the same as the clock rate of PXIN.
CLKOUT_10MHz	I1	O4, T	Clock output. Its clock rate is a half of the clock rate of PXIN.
MFG	E1	O2, T	Test pin
TEST_0	F1	I	Test pin
VDD	C3,C8,H9,I4	PWR	+3.3V core power
VCCIO	C4,C9,I3,I9	PWR	+3.3V I/O power



Pin Name	Pin No.	Type	Description
GND	A1,A11,B2, B10,J10, K1, K2, K11	GND	Ground

**Buffer Type Descriptions**

BUFFER	DESCRIPTION
I	Input pin
U	Internal weak pull-up resistor
D	Internal weak pull-down resistor
T	Tri-state
B4	Bi-directional pin with 4 mA drive
B8	Input/output with 8 mA drive
O4	Output pin with 4 mA drive
O8	Output pin with 8 mA drive
ICLK	XTAL clock input
OCLK	XTAL clock output
PWR	Power pin
GND	Ground pin



## 6. Electrical Characteristics

### Absolute Maximum Ratings

SYMBOL	PARAMETER	RATING	UNITS
$V_{CC}$	Power Supply	-0.3 to 3.6	V
$V_{IN}$	Input Voltage	-0.3 to $V_{CC}+0.3$	V
$V_{OUT}$	Output Voltage	-0.3 to $V_{CC}+0.3$	V
$T_{STG}$	Storage Temperature	-55 to 150	°C

### Recommended Operation Conditions

SYMBOL	PARAMETER	MIN	TYP	MAX	UNITS
$V_{CC}$	Power Supply	3.0	3.3	3.6	V
$T_{OPR}$	Operating Temperature	0	25	70	°C

### DC Electrical Characteristics for 3.3 volts operation

(Under Recommended Operating Conditions and  $V_{CC} = 3.0V \sim 3.6V$ ,  $T_j = 0^\circ C$  to  $+70^\circ C$ )

SYMBOL	PARAMETER	CONDITIONS	MIN	TYP	MAX	UNITS
$V_{IL}$	Input Low Voltage		-0.3		0.8	V
$V_{IH}$	Input High Voltage		2.0		$V_{CC}+0.3$	V
$V_{T-}$	Schmitt Input Low Voltage		-0.3		0.8	V
$V_{T+}$	Schmitt Input High Voltage		2.0		$V_{CC}+0.3$	V
$V_{OL}$	Output Low Voltage	$I_{OUT} = -4mA$			0.4	V
$V_{OH}$	Output High Voltage	$I_{OUT} = 4mA$	2.4			V



### 7. Package Diagrams

Ball Pitch 310um	A	B	C	D	E	F	G	H	I	J	K
1	GND	/CF_CD0	CF_D9	CF_D8	MFG	TEST_0	CF_A2	CF_A3	CLKOUT_10 MHZ	IDE_JORDY	GND
2	PXIN	GND	CF_D10	CF_D1	CF_A0	CF_A1	/CF_INPACK	CF_A4	CLKOUT_20 MHZ	CF_WII	GND
3	IDE_DMARQ	PXOUT	VDD	CF_D2	CF_D0	/CF_REG	/CF_WAIT	CF_RESET	VCCIO	CF_A10	/CF_IORD
4	IDE_A2	/IDE_DMACK	VCCIO						VDD	/CF_OE	/CF_IOWR
5	IDE_IRQ	IDE_A0	IDE_A1						CF_A9	CF_A8	/CF_WE
6	/IDE_IOW	/IDE_IOR	/CF_CD1						N.C.	CF_A7	CF_RII
7	IDE_D0	IDE_D15	IDE_D14						CF_A5	CF_A6	N.C.
8	IDE_D1	IDE_D13	VDD						CF_CS0	CF_D7	CF_CS1
9	IDE_D12	IDE_D2	VCCIO	IDE_D3	/IDE_RESET	SIO_CLK	CF_D3	VDD	VCCIO	CF_D6	CF_D15
10	IDE_D4	GND	IDE_D10	IDE_D6	IDE_D11	/PORST	SIO_DATA	CF_D12	CF_D13	GND	CF_D14
11	GND	IDE_D5	IDE_D9	IDE_D8	IDE_D7	SIO_ENABLE	POWERON	CF_D11	CF_D4	CF_D5	GND

Looking at bumps (bottom side).



Street Width X:  , Y:  um  
Chip Size X:  , Y:  um  
Chip Array in one Shot (Reticle) X:  , Y:   
Step Pitch X:  , Y:  um

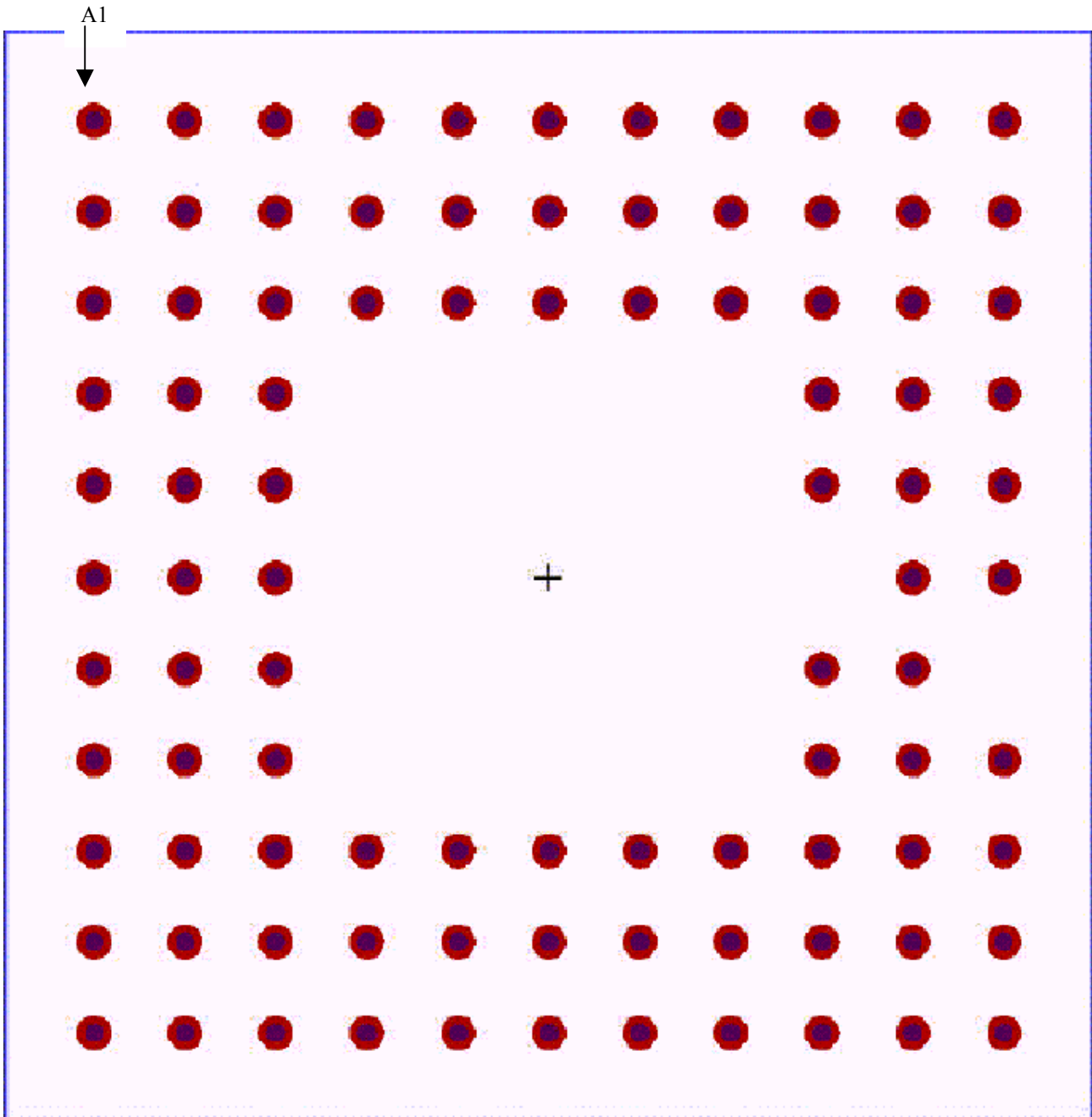



---

## JEILIN Technology Co., Ltd.

8F, No. 179, Jian Yi Rd., Chung Ho,  
Taipei Hsien, Taiwan

Tel: 886-2-8221-5466

Fax: 886-2-8221-5456

Website: [www.jeilin.com.tw](http://www.jeilin.com.tw)

Email: [jeilin@jeilin.com.tw](mailto:jeilin@jeilin.com.tw)

©2005 JEILIN Technology Corp., Ltd. All rights reserved.

*The information in this document has been carefully checked and is believed to be reliable; however no responsibility can be assumed for inaccuracies that may not have been caught. All information in this document is subject to change without prior notice. The information contained in this document is presented only as a guide for applications of our products. No responsibility is assumed by JEILIN Technology for any infringements of intellectual property or other rights of the third parties, which may result from its use. No license is granted by implication or otherwise under any intellectual property or other rights of JEILIN Technology or others. No part of this document may be reproduced in any form, in an electronic retrieval system or otherwise, without the prior written permission of JEILIN Technology.*